

SmartFan® Cirrus-6

DC Controller for PWM Speed Controllable (4-Wire) Fans

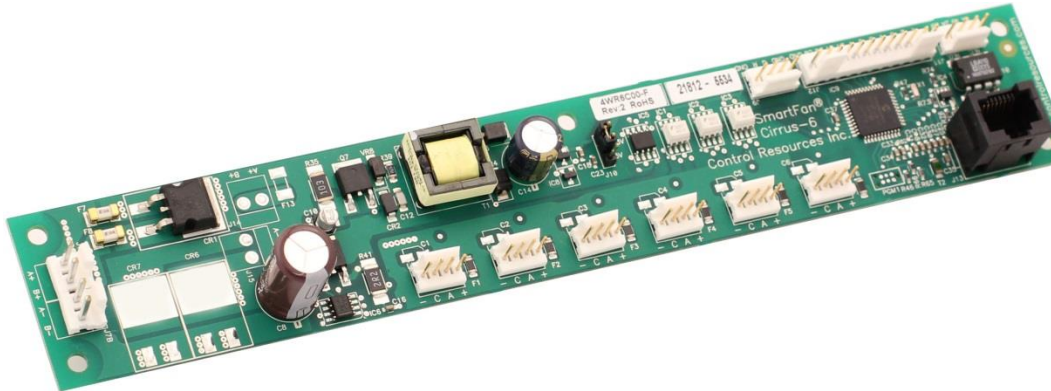

SmartFan® Cirrus-6



Navigator
Programmer

SmartFan® Cirrus-6 is an off-the-shelf, customer programmable fan controller designed to manage and monitor up to six 12, 24 or 48VDC 4-wire fans or blowers. Users can create their own temperature control curve, temperature alarm trigger point, low speed alarm trigger point, fail safe modes and more. For autonomous temperature control, the SmartFan Cirrus-6 can be configured using the Navigator PRG00-F hand-held, menu-driven remote programmer (pictured above). For systems with I2C, the Cirrus-6 offers options to adjust temperature control and alarm parameters or directly control fan speed. Factory customization available for quantities as low as 50 pieces (See page 2 for customization options).

Part #	Current Rating (60°C)	Input Power	4-Wire Fan Signal Type
4WR6C00-F	6 Amps	Single or Dual	Open Collector PWM
4WR6V00-F	6 Amps	Single or Dual	0-12VDC PWM
4WR12C00-F	12 Amps	Single only	Open Collector PWM
4WR12V00-F	12 Amps	Single only	0-12VDC PWM
H125-F	Hardware Pack (recommended for lower volume applications)		
PRG00-F	Navigator remote programmer. Required to program the controller when not connected to an I2C bus.		
Temp Sensors	To sense temperatures off the board, choose a temperature sensor from www.controlresources.com/sensors .		

Specifications

- Power Source: 10-60VDC, single or Dual diode OR'd feed
- Extended Voltage ratings: Up to 76VDC can be achieved when used with the SmartFan® Multi SD or Storm regulator
- Max Fan Current: 4 Amps per fan, 12 Amps total (4WR12x00-F only)
- Compatible Fans: Up to six 12, 24 or 48VDC 4-wire fans (open collector PWM or 0-12VDC PWM)
- On board 3.3/5VDC isolated power for I2C and other control signals
- Control temp accuracy & hysteresis: $\pm 2^{\circ}\text{C}$
- Operating Environment: -20 to 60°C, 0-95% RH
- Storage Temperature: -40 to 125°C
- Weight: 53 grams (1.9oz)

Factory Customization Options

- Up to 3 temperature sensors
- Analog control signals (i.e. 4-20mA, 0-5VDC...)
- Individual fan fusing

- Custom diode ORing
- Conformal coating

Features

- Control Signals & Programming Modes
 - I2C interface: Used to control speed or adjust temperature control parameters
 - Temperature control parameters can be programmed using the Navigator remote programmer PRG00-F
- Status and Alarm Reporting
 - Fan speed, temperature and alarm conditions are programmable through I2C interface and reported through I2C, LED or MOS relay connections
 - Temperature alarms and fan speed alarms are programmable with Navigator remote programmer and reported through LED or MOS relay
- Factory programming for orders as low as 50 units
- 2 year warranty
- Made in the USA
-  Certified. Ref. Installation section for conditions of acceptability.

DIMENSIONS (fig. 1)

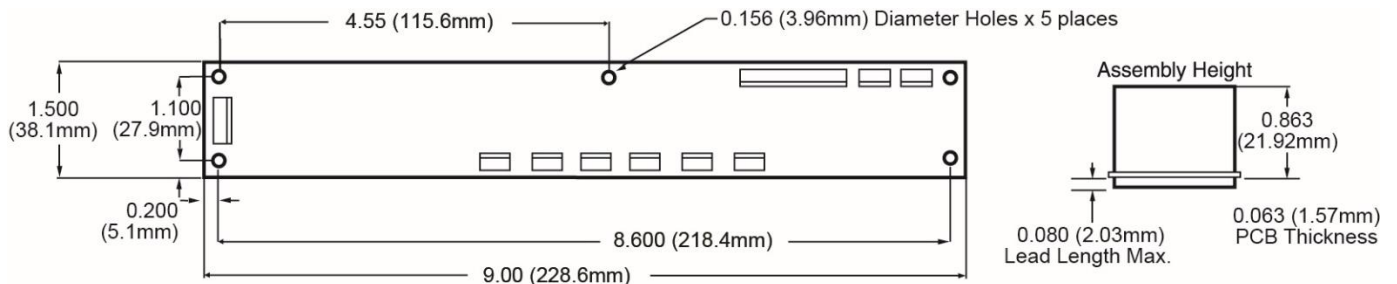

INSTALLATION

MOUNTING

When mounting over a conductive surface, use a minimum spacer height of 5mm (.197”) for proper electrical clearance. The Cirrus 6 meets EU directives EN 60950-1 for safety and EN6100 class A for Emissions and Immunity when mounted in a conductive enclosure vented to limit finger access to the board and to maintain an operating temperature of 60°C or less. For your convenience in lower volume applications, CRI sells an optional hardware pack, H125-F that includes typical connectors and mounting hardware (see below).

Table 1: Recommended Hardware				
Header	Mfg. & P/N	H125-F Hardware Pack		
		Qty	Description	Mfg. & Part No. ¹
J7	Molex No. 26-60-4040	1	Housing	Molex No. 09-50-8041
		4	Terminal (tin)	Molex No. 08-52-0072
J14 ²	Molex No. 26-60-4020	1	Housing	Molex No. 09-50-8021
		2	Terminal (tin)	Molex No. 08-52-0072
J1 - J6	Molex No. 22-29-2041	6	Housing	Molex No. 22-01-3047
		24	Terminal (gold)	Molex No. 08-55-0102
J12	Molex No. 22-29-2121	1	Housing	Molex No. 22-01-3127
		12	Terminal (gold)	Molex No. 08-55-0102
J9 & J11	Molex No. 22-29-2041	2	Housing	Molex No. 22-01-3047
		8	Terminal (gold)	Molex No. 08-55-0102
		5	PCB Support	Essentra No. CBS-4-19

¹ Or equivalent

² Used for 12A Models only

CONNECTIONS

Refer to table 1, figure 2, table 2 and the paragraphs below to connect your Cirrus 6.

Fan Connections (J1-J6)

Cirrus-6 distributes power to and monitors the tachometer signals from up to six four-wire fans. Fan current at each fan header must not exceed 4 Amps. Total fan current must not exceed the current rating of the Cirrus-6 model being used.

Input Power J7A/J7B (4WR6C00-F, 4WR6V00-F)

Connect single or dual 10-60VDC supplies to J7. For one supply, connect to A+ and A-, for dual supplies; connect the second supply to B+ and B-.

Input Power J7B/J14 (4WR12C00-F, 4WR12V00-F)

Connect a single 10-60VDC supply only to J7B and J14. When total fan current exceeds 6 Amps, make sure to connect supply to all 4 positive and negative pins.

Controller Status LED Connection J9 (Optional)

Header J9 provides local indication of Alarm (Red LED, Pin R) and Normal (Green LED, Pin G) status. Choose 2 single color LEDs or 1 bi-color LED (2 leaded) with a rated forward voltage (V_f) between 1.6 and 2.4 VDC at a forward current (I_f) of between 15 and 25 mA. Nominal current applied to the LEDs is 8 mA.

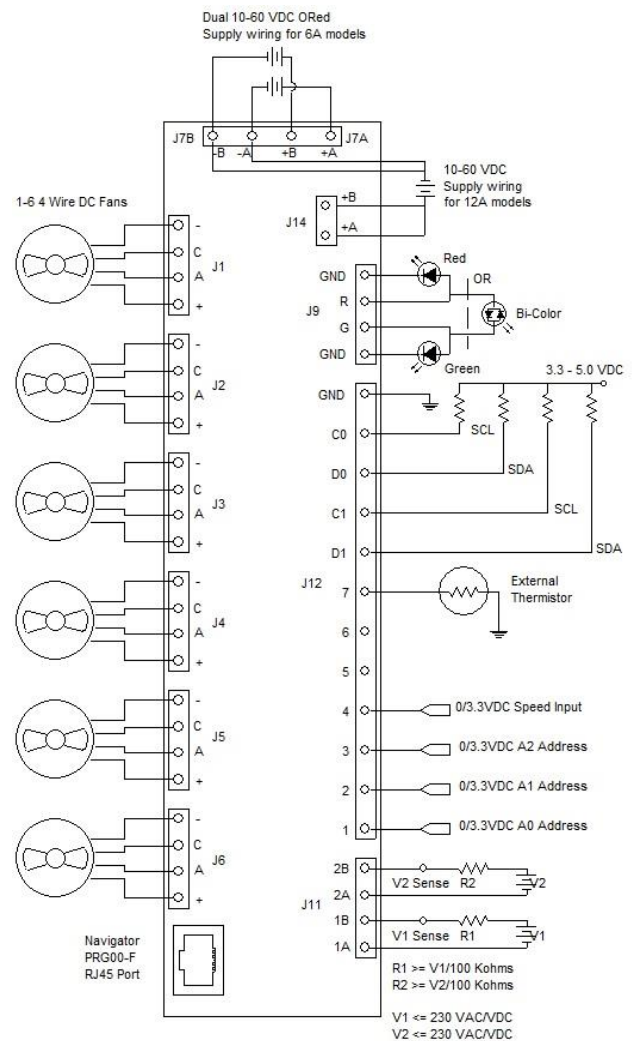

Figure 2: Connection diagram

Connection of MOS Relay Alarm J11 (Optional)

A dual MOS relay is provided on header J11. Pins 1A and 1B output is closed on no alarm. Pins 2A and 2B output is open on no alarm. The alarm circuits on header J11 are isolated from all other pins and have no polarity. These outputs have a maximum on-state resistance of 50Ω. Maximum sinking current is 100mA. A maximum of 230 VAC/VDC can be applied to alarm terminals.

Remote Temperature Sensor J12 (Optional)

All Cirrus 6 models come with an on board temperature sensor (T2) that can be used for monitoring board temperature or controlling fan speed based on temperature. The Cirrus-6 can also be configured to operate with an external sensor (sold separately, reference www.controlresources.com/sensors). There is no polarity consideration when connecting the sensor. Temperature accuracy and hysteresis is 2°C.

Speed Override Input J12 (Optional)

A logic level input is located on J12 that allows the user to command the fans to full speed when pin 4 is tied to GND. If this input is set to VCC or left open, then the speed is set by its normal operating mode. Default is 100% and can be adjusted with the **Navigator**.

I2C Bus Connection J12 (Optional)

The Cirrus-6 can be used with or without I2C communications. When no I2C is present, the Cirrus 6 will control fan speed by sensing temperature, programming is done via the SmartFan® Navigator hand-held programmer, no additional connections to J12 are required. When using I2C communications to program, control and monitoring is provided by a dual or single I2C Bus on pins C0, D0, C1, D1, see “I2C Programming and Control” section for details. Note: I2C settings are independent from Navigator settings. I2C settings are not stored. If no system I2C is present use the Navigator option for programming.

Table 2: Connector Pin Assignments		
Header	Label	Description
J7 / J14	A+	A Power Supply Positive Terminal
	B+	B Power Supply Positive Terminal
	A-	A Power Supply Negative Terminal
	B-	B Power Supply Negative Terminal
J1- J6	-	Fan, Negative Terminal
	C	Fan, Speed Control Signal
	A	Fan, Tachometer Signal
	+	Fan, Positive Terminal
J9	GND	Green LED Cathode
	G	Green LED Anode
	R	Red LED Anode
	GND	Red LED Cathode
J12	1	I2C Address A0
	2	I2C Address A1
	3	I2C Address A2
	4	Speed Override Input
	5	Not Used
	6	Not Used
	7	External Thermistor Input
	D1	SDA for Secondary I2C Bus
	C1	SCL for Secondary I2C Bus
	D0	SDA for Primary I2C Bus
	C0	SCL for Primary I2C Bus
	GND	Isolated/Logic Ground
J11	1A	NC MOS Relay
	1B	NC MOS relay
	2A	NO MOS Relay
	2B	NO MOS Relay

PROGRAMMING FOR TEMPERATURE CONTROL

Cirrus-6 can be programmed using a Navigator PRG00-F programmer (www.controlresources.com/navigator) or controlled and adjusted using an IC2 bus. If using an I2C system bus, skip this section and go directly to [I2C PROGRAMMING & CONTROL](#). Cirrus-6 can also be preprogrammed at the factory in production volumes at no additional cost, contact CRI customer service for details.



Navigator Handheld Remote Programmer

Refer to figure 2 and table 3 below to develop and program your temperature control curve.

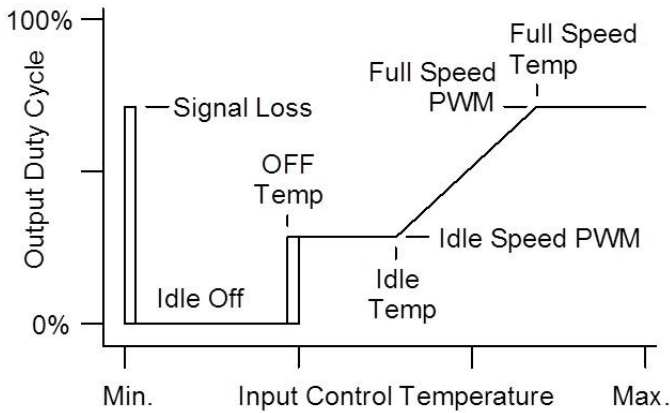

Figure 3: Fan speed signal vs. sensor temperature.

Table 3: Cirrus-6 Navigator Menu				
		Options	Selection	Default
SYSTEM SETTINGS	NUMBER OF FANS		1 - 6	6
	TEMP SENSOR		External / On Board	External
	SPEED ON SIGNAL LOSS		Full / Idle	Full
CONTROL SETTINGS	PWM FREQUENCY		2.5kHz / 5.0kHz / 10kHz / 20kHz	2.5kHz
	FULL SPEED PWM		100% - 0%	100%
	IDLE SPEED PWM		0% - 100%	55%
	IDLE TEMP		-20°C to 80°C	35°C
	FULL SPEED TEMP		80°C to -20°C	40°C
ALARM SETTINGS	OFF TEMP		-20°C to 80°C / Disabled	Disabled
	TACH TRIP POINT		No Alarm / 1000 / 2000 / 4000 PPM	2000 PPM
	ALARM TEMP		80°C to -20°C / Disabled	Disabled
	SELECT PROBE		P, S	P-Series

NAVIGATOR PROGRAMMING

1) Connect Navigator to the Cirrus-6 through the RJ45 connectors using the Ethernet cable supplied. Apply power to the Cirrus-6 to enable programming via the Navigator. See table 3 for a description of each programming option.

2) Navigator will display its current revision briefly then it will show the product type connected.

Cirrus-6
is ready

3) Select the number of fans (1-6) connected. The value is adjusted with the ▲ or ▼ keys and the **Next** key will bring you to the next parameter.

Set # of fans,
→6

Note: At any time the **Previous** key can be used to go back to the previous menu and the **Write Drive**

key can be used to save all the settings in the Cirrus-6.

4) Use the ▲ or ▼ keys to select the On-Board temp. sensor or External temp. sensor (connected at J12 pin 7 & GND) to be used for temperature control. press the **Next** key to go to the next parameter.

Temp Sensor
→External

5) The Speed on signal loss menu is used to set a fail-safe fan speed in case the control signal is lost. At this point, it is highly recommended that you start drawing your desired control curve to help identify the programmable variables to follow (refer to figure 3 to model you control curve).

A setting of “Full” will simulate a Control Input setting equal to that programmed in the “Full Temp” menu, (see paragraph 10). A setting of “Idle” will simulate an “Idle Temp.” setting of -25° (see paragraph 9).

Note: Selecting “idle” upon signal loss will turn fans off when a low temperature shut-off is programmed in step 11.

Speed on signal
loss →Full

Once the desired speed is displayed, press the **Next** key.

6) Use the ▲ or ▼ keys to select the PWM frequency. The options are 2.5kHz, 5.0kHz, 10kHz, or 20kHz. Refer to the fan specification for the recommended frequency. Once the desired frequency is displayed, press the **Next** key.

Set PWM freq.
→2.50kHz

7) Use the ▲ or ▼ keys to adjust the full speed for the fan or motor. This sets the PWM duty cycle from 0% to 100% in 1% increments. Once the desired output duty cycle is displayed, press the **Next** key.

Set full speed
→100%

8) Use the ▲ or ▼ keys to adjust the idle speed for the fan or motor. This sets the PWM duty cycle from 0% to 100% in 1% increments. Note the idle can be set higher than the full speed for heating applications or to compensate for fans with reverse slope input control curves. Once the desired output duty cycle is displayed, press the **Next** key.

Set idle speed
→ 55%

9) Use the ▲ or ▼ keys to select the temperature at which you want the fans to idle. Options are between -20°C and 80°C with 1° steps. Once the desired temperature is displayed, press the **Next** key.

Set idle temp.
→ 35C

10) Use the ▲ or ▼ keys to select the temperature at which you want the fans to reach full speed. Options are between -20°C and 80°C with 1° steps. Once the desired temp. is displayed, press the **Next** key.

Set full temp.
→40C

11) Use the ▲ or ▼ keys to select the temperature at which you want the fans to turn off. Options are between -20°C and 80°C with 1° steps or “Disabled”. Fans will not turn off (as long a power is applied) when “Disabled” is selected. Once

the desired level is displayed, press the **Next** key.

Set off temp.
→Disabled

12) Use the ▲ or ▼ keys to select the tachometer alarm trip point. When fan speed falls below the trip point, the alarm output will be activated and the PWM will be forced to full speed. The options are “No Alarm”, 1000PPM, 2000PPM, and 4000PPM. PPM (pulses per minute) = RPM x PPR (pulses per revolution). “No Alarm” disables the tachometer alarm. Once the desired trip point is displayed, press the **Next** key.

Set tach trip
point →2000 PPM

13) Use the ▲ or ▼ keys to select the temperature at which you want an alarm to be triggered. Options are between -20°C and 80°C with 1° steps or “Disabled”. Once the desired level is displayed, press the **Next** key.

Set alarm temp.
→Disabled

14) For Rev: 3.3 and above, when controlling fan speed based on external temperature, the user can select the type of Control Resources temperature sensor connected to J12. Use the ▲ or ▼ keys to select the probe series (P or S). Note: Older revisions must use the P-Series sensors only. Press the **Next** key to continue.

Select Probe
→ P-Series

15) Cirrus-6 will now cycle back to the “Set # of Fans” screen. To review the existing parameters of a programmed Cirrus-6, scroll through parameters using the **Next** or **Previous** keys. Parameters can be changed at any time using the ▲ or ▼ keys.

16) Once all parameters are correct, press the **Write Drive** key to save the settings to the Cirrus-6. Disconnecting power from the Cirrus-6 before pressing **Write Drive** will discard any changes and reload the parameters from its previous memory.

OTHER NAVIGATOR FUNCTIONS

Refer to the instructions that came with your Navigator or down the datasheet from www.controlresources.com/navigator to learn how to:

- Copy a program from one Cirrus 6 to another
- Save a program to Navigator memory
- Customize a program name
- Recall a program from Navigator memory

I2C PROGRAMMING & CONTROL

When an I2C speed command is given, the Cirrus-6 automatically switches to I2C control mode for fan control via the I2C Bus. The speed of all fans is mapped to the command sent through the I2C on header J12. Note: Navigator settings are ignored in I2C mode and vice versa.

I2C Bus Protocol

The I2C Bus is configured as a slave device that can transmit and receive data. When the Cirrus-6 is configured for I2C based speed control, the user can write speed commands to the Cirrus-6 and read all alarm status bits. When configured for temperature based control the user can read all alarm status bits from the Cirrus-6. Writing an I2C speed command changes the control mode from temperature based to I2C based.

Specifications

- The Bus supports seven-bit addressing and only acts as a slave device.
- The address for the fan controller is 0001A₂A₁A₀.
- General call support is not provided.
- The fan controller will stretch the clock further if needed. The I2C master must observe clock stretching.
- The hardware register will support Standard Mode I2C with speeds up to 100 KHz, however, lower clock speeds are recommended for increased noise immunity.
- If temperature control mode is disabled and I2C speed mode is used, then I2C communication must occur within ~2 minutes of the last communication, or there will be an I2C communication timeout error. When an I2C timeout occurs, full speed will be applied to the fans, and fan speed must be reset with a new speed command. Performing any valid I2C operation on either bus will clear the timeout condition and restart the watchdog timer.
- Fan failure based on 2000 minimum PPM of fan in slow (default) mode or 4000 minimum PPM in fast mode. Fan failure is not updated when the output is set to 0%.
- It is possible for noise to cause the I2C hardware to miss an address or data. In this case an Ack will not be generated. The production tester allows 3 errors to occur before marking the board as failing. Also during the EEPROM write cycle the I2C will not generate ACK signals as no more data can be accepted until the write cycle is complete. Typical write cycle is 8ms.
- I2C specifies a maximum sink current of 5 ma and maximum bus capacitance of 400 pF.

Table 4: I ² C Bus Definitions	
ACK	Acknowledge
ACK	Not Acknowledge (End of Transmission)
A6 – A0	Address for Fan Controller, bits 6 – 0
D7 – D0	Data TO/FROM Fan Controller, bits 7 – 0
L7 – L0	Data location being accessed, bits 7-0
P	Stop Bit
R	Read Bit (1)
S	Start Bit
W	Write Bit (0)

On Board Power Supply

An isolated 3.3/5.0 VDC is provided on board to power the I2C Bus and control signal interfaces. The jumper on J10 selects the logic VCC.

Using Sensors with I2C Configuration

Control temperature can be set through the I2C Bus. When configured to operate with a remote external temperature sensor, choose a compatible SmartFan Sensor shown at www.controlresources.com/sensors. Control temperature can also be set through the I2C for the board-mounted temperature sensor.

Digital Inputs

The Speed input (Pin 4) and the ID inputs (Pins 1 - 3) are internally pulled to 3.3 VDC or 5.0 VDC with 10.0KΩ resistors.

GND (Pin GND)

The ground reference pin is for the I2C Busses and digital inputs only.

Write sequence

S A6 A5 A4 A3 A2 A1 A0 W Ack L7 L6 L5 L4 L3 L2 L1
L0 Ack D7 D6 D5 D4 D3 D2 D1 D0 Ack P

Read sequence

S A6 A5 A4 A3 A2 A1 A0 W Ack L7 L6 L5 L4 L3 L2 L1
L0 Ack P S A6 A5 A4 A3 A2 A1 A0 R Ack D7 D6 D5 D4
D3 D2 D1 D0 Ack P

Register Locations: L7-L0 Label (R/W) [initial condition]

Register 0x00 – 0xEF: Generic EEPROM storage (Read/Write) [undetermined]

Register 0xF0: Firmware Revision (Read only) [current rev]

Table 4 defines the bits used in the serial bus protocol.

Register 0xF1: Alarm0 Status (Read only) [0x00]

D0: Status of fan on J1 (0=no fault, 1= fault)
D1: Status of fan on J2 (0=no fault, 1= fault)
D2: Status of fan on J3 (0=no fault, 1= fault)
D3: Status of fan on J4 (0=no fault, 1= fault)
D4: Status of fan on J5 (0=no fault, 1= fault)
D5: Status of fan on J6 (0=no fault, 1= fault)
D6: Always 0
D7: Always 0

Register 0xF2: Alarm1 Status (Read only) [0x00]

D0: Always 0
D1-3: Always 0
D4: Status of speed override (0=normal, 1=100%)
D5: Status of on-board sensor (0=connected, 1=open)
D6: Status of external sensor (0=connected, 1=open)
D7: Status of controlling sensor (0=valid, 1=alarm)

Register 0xF3: Temperature (Read only) [1111 1111] on-board sensor

D0-7: Temperature from 0 - 70 in degrees C in 0.5 deg steps
0xFF = temperature not read yet or open (Temperatures above 70 are reported as 254)

Register 0xF4: Temperature (Read only) [1111 1111] external sensor

D0-7: Temperature from 0 - 70 in degrees C in 0.5 deg steps
0xFF = temperature not read yet or open (Temperatures above 70 are reported as 254)

Register 0xF5: Current Target Speed (Read only) [0001 0100]

D0-7: 0x14 = 100%, 0x00 = 0%
(Commanded speed with alarm status override included)
(In temperature mode this register will read 0x14)

Register 0xF6: Current Speed (Read only) [0001 0100]

D0-7: 0x14 = 100%, 0x00 = 0%
(What the actual current voltage is)
(In temperature mode this register will read 0x14)

Register 0xF7: Commanded Speed (Read/Write) [1111 1111]

D0-7: 0x14 = 100%, 0x00 = 0%
0x00 – 0x14 = 0 – 100 %, 5% per step
If set to 0xFF then temperature mode is enabled and I2C speed control disabled

Register 0xF8: Off Temperature (Read/Write) [1111 1111]

D0-7: Temperature from 0 - 70 in degrees C in 0.5 deg steps

Temperature below which the controller turns off the fan output (0% PWM)

If set to 0xFF then function disabled

Register 0xF9: Control Temperature (Read/Write) [0101 0000]

D0-7: Temperature from 0 - 70 in degrees C in 0.5 deg steps
Full speed temperature is only used if Commanded Speed set to 0xFF.

Register 0xFA: Alarm Temperature (Read/Write) [1111 1111]

D0-7: Temperature from 0 - 70 in degrees C in 0.5 deg steps
Temperature above which the controller alarms
If set to 0xFF then function disabled

Register 0xFB: Config0 Register (Read/Write) [0011 1111]

D0-D5: 0=Mask, 1=Active for Fan (J1-J6)
D6-D7: Not Used

Register 0xFC: Config1 Register (Read/Write) [0000 0000]

D0: Not Used
D1-D3: Set to 0, may be set to 1 to allow system to indicate a fan controller reset.
D4: Probe type, 0=P series, 1=S series
D5: 0=5deg slope, 1=10 deg slope for temperature mode only
D6: 0=2000PPM tach, 1=4000PPM tach fan alarm speed
D7: 0=External, 1=On-board sensor selection for temperature mode only

Register 0xFD-0xFF: CRI Test Register (Reserved) [xxxx xxxx]

D0-7: Do not use

Note: If a fan failure occurs the Current Speed will be updated to full but the Commanded Speed will remain at its previous value. Once the failure clears the Current Speed will return to the Commanded Speed value. An I2C timeout changes BOTH the Current Speed and Commanded Speed to full. The Commanded Speed must be reset after a timeout. During the speed ramp the Current Speed will not match the Commanded Speed until the ramp completes.